

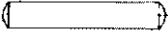



Abbildung	Artikel	Bezeichnung
	DIN 1 ISO 2339	Kegelstifte Taper pins Goupilles coniques Pasadores conicos Spine coniche
	DIN 7 ISO 2338	Zylinderstifte, Form A (Toleranzfeld m 6) Parallel pins Goupilles cylindriques Pasadores cilindricos Spine cilindriche
	DIN 84 ISO 1207	Zylinderschrauben mit Schlitz Slotted cheese head screws Vis à tête cylindrique fendue Tornillos de cab. cil. con ranura longitudinal Viti testa cilindrica taglio cacciavite
	DIN 85 ISO 1580	Flachkopfschrauben mit Schlitz Slotted pan head screws Vis à tête cylindrique à dépouille fendue Tornillos de cabeza alomada con ranura longitudinal Viti testa cilindrica con calotta taglio cacciavite
	DIN 93	Sicherungsbleche mit 1 Lappen Tabwashers with 1 tab Freins d' écrous à un aileron Arandelas de seguridad con solapa Placchette di sicurezza
	DIN 94 ISO 1234	Splinte Split pins Goupilles fendues Pasadores de aleta Copiglie
	DIN 95	Linsensenk-Holzschrauben mit Schlitz Slotted raised countersunk head wood screws Vis à bois à tête fendue fraisée bombée Tornillos para madera gota de sebo con ranura longitudinal Viti a legno testa svasata con calotta taglio cacciavite

Abbildung**Artikel****Bezeichnung**

DIN 908

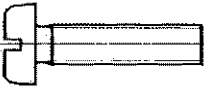
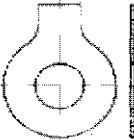
Verschlußschrauben mit Bund und Innensechskant, metrisches Feingewinde nach DIN 13
Hexagon socket pipe plugs, metric fine pitch according to DIN 13
Bouchons filetés avec épaulement et six pans creux, filet fin métrique à la DIN 13
Tapones cilindricos hexagono interior y cuello, rosca metrica paso fino según DIN 13
Tappi cilindrici con spallamento ed esagono interno, filetto metrico passo fine secondo DIN 13

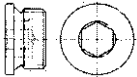
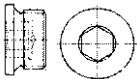

DIN 908

Verschlußschrauben mit Bund und Innensechskant, zylindrisches Gasgewinde nach DIN 228
Hexagon socket pipe plugs, cylindrical thread according to DIN 228
Bouchons filetés cylindriques à collerette et à six pans creux, à la DIN 228
Tapones cilindricos hexagono interior y cuello, según DIN 228
Tappi cilindrici con esagono incassato e spallamento secondo DIN 228

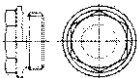

DIN 910

Verschlußschrauben mit Bund und Außensechskant, metrisches Feingewinde nach DIN 13
Hexagon head pipe plugs, cylindrical thread metric fine pitch according to DIN 13
Bouchons filetés cylindriques à tête hexagonale, à collerette, filet fin métrique à la DIN 13
Tapones cilindricos hexagono exterior y cuello, rosca metrica paso fino según DIN 13
Tappi cilindrici con spallamento ed esagono esterno filetto metrico passo fine secondo DIN 13





Abbildung	Artikel	Bezeichnung
	DIN 910	<p>Verschlussschrauben mit Bund und Außensechskant, zylindrisches Gasgewinde nach DIN 228</p> <p>Hexagon head pipe plugs, cylindrical thread, according to DIN 228</p> <p>Bouchons filetés cylindriques à tête hexagonale, à collerette; type large à la DIN 228</p> <p>Tapones cilíndricos hexagono exter. y cuello según DIN 228</p> <p>Tappi cilindrici con spallamento ed esagono esterno secondo DIN 228</p>
	DIN 912 ISO 4762	<p>Zylinderschrauben mit Innensechskant</p> <p>Hexagon socket head cap screws</p> <p>Vis à six pans creux, tête cylindrique</p> <p>Tornillos cab. cil. con hueco hexagonal</p> <p>Viti testa cilindrici con esagono incassato</p>
	DIN 913 ISO 4026	<p>Gewindestifte mit Innensechskant und Kegelkuppe</p> <p>Hexagon socket set screws with flat point</p> <p>Vis sans tête à six pans creux avec bout plat</p> <p>Esparragos allen y punta biselada</p> <p>Viti senza testa con cava esagonale</p>
	DIN 914 ISO 4027	<p>Gewindestifte mit Innensechskant und Spitze</p> <p>Hexagon socket set screws with cone point</p> <p>Vis sans tête à six pans creux avec bout pointu</p> <p>Esparragos allen y punta conica</p> <p>Viti senza testa con cava es. e punta conica</p>
	DIN 915 ISO 4028	<p>Gewindestifte mit Innensechskant und Zapfen</p> <p>Hexagon socket set screws with dog point</p> <p>Vis sans tête à six pans creux avec téton long</p> <p>Esparragos allen y punta cilíndrica</p> <p>Viti senza testa con esagono incassato e punta cilíndrica</p>
	DIN 916 ISO 4029	<p>Gewindestifte mit Innensechskant und Ringschneide</p> <p>Hexagon socket set screws with cup point</p> <p>Vis sans tête à six pans creux avec cuvette</p> <p>Esparragos allen y punta biselada hueco</p> <p>Viti senza testa con cava es. e punta coppa</p>



Abbildung	Artikel	Bezeichnung
	DIN 917	Sechskant-Hutmuttern, niedrige Form Hexagon cap nuts Ecrous borgnes hexagonaux bas Tuercas hexagonales ciegas Dadi esagonali ciechi con calotta sferica
	DIN 920	Flachkopfschrauben mit Schlitz und kleinem Kopf Slotted pan head screws with small head Vis à tête cylindrique à dépouille, fendue, réduite Tornillos cab. cilíndrica rebajada ranurada Viti a testa cilindrica ridotta taglio cacciavite
	DIN 921	Flachkopfschrauben mit Schlitz und großem Kopf Slotted pan head screws with large head Vis à tête cylindrique à dépouille, fendue, large Tornillos cab. cilíndrica ancha Viti a testa cilindrica larga con calotta
	DIN 923	Flachkopfschrauben mit Schlitz und Ansatz Slotted pan head screws with shoulder Vis à tête cylindrique à dépouille, fendue, à tige ajustable Torn. c/cil. ranurada garganta y cana apoyo Viti a testa cilindrica con spalla
	DIN 928	Vierkant-Schweißmuttern Square weld nuts Ecrous carrés à souder Tuercas cuadradas para soldar Dadi quadri a saldare
	DIN 929	Sechskant-Schweißmuttern Hexagon weld nuts Ecrous hexagonaux à souder Tuercas hexagonales para soldar Dadi esagonali a saldare
	DIN 931 ISO 4014	Sechskantschrauben mit Schaft Hexagon head bolts Vis à tete six pans Tornillos hexagonales parcialmente roscados Viti testa esagonale parzialmente filettate

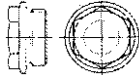

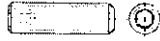
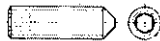
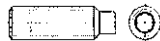

Abbildung	Artikel	Bezeichnung
	DIN 933 ISO 4017	Sechskantschrauben mit Gewinde bis Kopf Hexagon head screws Vis à tête six pans Tornillos hexagonales todos roscados Viti testa esagonale interamente filettate
	DIN 933 sz ISO 4017	Sechskantschrauben mit Schlitz Slotted hexagon head screws Vis à tête six pans avec fente Tornillos hexagonales con ranura longitudinal Viti testa esagonale interamente filettate taglio cacciavite
	DIN 934	Sechskantmuttern Hexagon nuts Ecrous hexagonaux Tuercas hexagonales Dadi esagonali medi
	ISO 4032	Sechskantmuttern Hexagon nuts Ecrous hexagonaux Tuercas hexagonales Dadi esagonali medi
	DIN 934	Sechskantmuttern 1.4571 Hexagon nuts Ecrous hexagonaux Tuercas hexagonales Dadi esagonali medi
	DIN 934	Sechskantmuttern mit Linksgewinde Hexagon nuts left hand thread Ecrous hexagonaux à gauche Tuercas hexagonales, rosca izquierda Dadi esagonali medi, filettatura sinistra
	DIN 934	Sechskantmuttern mit Feingewinde Hexagon nuts, fine pitch Ecrous hexagonaux, filet fin métrique Tuercas hexagonales, rosca fina Dadi esagonali medi, passo fine
	DIN 935 ISO 7035	Kronenmuttern Hexagon castle nuts, slotted Ecrous hexagonaux à créneaux Tuercas hexagonales almenadas Dadi esagonali a corona



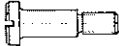
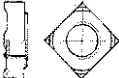
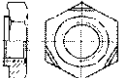
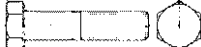

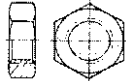
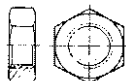
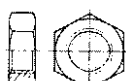
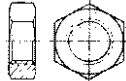

Abbildung	Artikel	Bezeichnung
	DIN 936	Sechskantmuttern, niedrige Form Hexagon thin nuts Ecrous hexagonaux, bas Tuercas hexagonales bajas Dadi esagonali bassi
	DIN 936	Sechskantmuttern, niedrige Form, Feingewinde Hexagon thin nuts, fine pitch Ecrous hexagonaux, bas, filet fin métrique Tuercas hexagonales bajas, rosca fina Dadi esagonali bassi, passo fine
	DIN 937	Kronenmuttern, niedrige Form Thin hexagon castle nuts, slotted Ecrous hexagonaux à créneaux, bas Tuercas hexagonales almenadas bajas Dadi esagonali a corona bassi
	DIN 938	Stiftschrauben, Einschraubende ~ 1 d Studs, metal end ~ 1 d Goujons filetés, partie filetée ~ 1 d Esparragos-parte roscada ~ 1 d Viti prigioniere ~ 1 d
	DIN 939	Stiftschrauben, Einschraubende ~ 1,25 d Studs, metal end ~ 1,25 d Goujons filetés partie filetée ~ 1,25 d Esparragos-parte roscada ~ 1,25 d Viti prigioniere sede fissa all 'estremità d'awitamento ~ 1,25 d
	DIN 963 ISO 2009	Senkschrauben mit Schlitz Slotted countersunk head screws Vis à tête fraisée fendue Tornillos avellanados con ranura longitudinal Viti testa piana svasata taglio cacciavite
	DIN 964 ISO 2010	Linsensenkschrauben mit Schlitz Slotted raised countersunk head screws Vis à tête fraisée bombée fendue Tornillos gota de sebo con ranura longitudinal Viti testa svasata con calotta taglio cacciavite

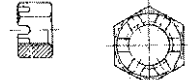
Abbildung	Artikel	Bezeichnung
	DIN 965 H ISO 7046	Senkschrauben mit Kreuzschlitz H - Phillips Cross recessed countersunk (flat) head screws - H Vis à tête fraisée à empreinte cruciforme - H Tornillos avellanados mortaja cruzada - H Viti testa piana svasata taglio croce - H
	DIN 965 Z ISO 7046	Senkschrauben mit Kreuzschlitz Z - Pozidrive Cross recessed countersunk (flat) head screws - Z Vis à tête fraisée à empreinte cruciforme - Z Tornillos avellanados mortaja cruzada - Z Viti testa piana svasata taglio croce - Z
	DIN 965 TX ISO 7046	Senkschrauben mit Innenvielzahn Countersunk (flat) head screws, six lobe drive Vis à tête conique, fraisée, à six lobes intérieurs Tornillos avellanados mortaja, multiestrella Viti testa piana svasata, esalobate
	DIN 966 H ISO 7047	Linsen-Senkschrauben mit Kreuzschlitz H - Phillips Cross recessed raised countersunk head screws - H Vis à tête fraisée bombée à empreinte cruciforme - H Tornillos gota de sebo mortaja cruzada - H Viti testa svasata con calotta taglio croce - H
	DIN 966 Z ISO 7047	Linsen-Senkschrauben mit Kreuzschlitz Z - Pozidrive Cross recessed raised countersunk head screws - Z Vis à tête fraisée bombée à empreinte cruciforme - Z Tornillos gota de sebo mortaja cruzada - Z Viti testa svasata con calotta taglio croce - Z
	DIN 975	Gewindestangen, Länge l = 1 m Threaded rods Tiges filetées Varillas roscadas Barra filettata

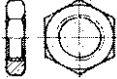
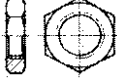
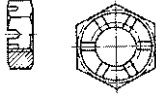
Abbildung**Artikel****Bezeichnung**

DIN 975

Gewindestangen mit Linksgewinde,
Länge $l = 1$ m
Threaded rods left hand thread
Tiges filetées à gauche
Varillas roscadas, izquierda
Barra filettata, sinistra

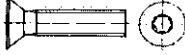
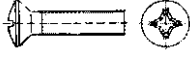
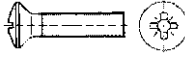
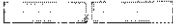
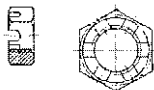

DIN 979

Kronenmuttern, niedrige Form
Thin hexagon castle nuts, slotted
Ecrous hexagonaux à créneaux, bas
Tuercas hexagonales almenadas bajas
Dadi esagonali a intagli

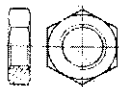

~ DIN 980

Sechskantmuttern, selbstsichernd
mit Klemmteil, Ganzmetallmuttern,
verformt aus DIN 934
Prevailing torque type hexagon nuts,
all-metal nuts
Ecrous auto-freinés hexagonaux,
écrous tout metal
Tuercas hex. de autoseguro todo metal
Dadi esagonali autobloccanti interamente
in metallo

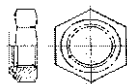

DIN 982

Sechskantmuttern, mit nichtmetallischem
Klemmteil, hohe Form
Prevailing torque type hexagon nuts
with non-metallic insert, high type
Ecrous auto-freinés hexagonaux
avec insert non-metallique, type haut
Tuercas hex. de autoseguro altas,
con arandela plastica
Dadi esagonali autobloccanti alti con inserto
non metallico

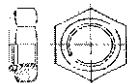

DIN 985

Sechskantmuttern, mit nichtmetallischem
Klemmteil, niedrige Form
Prevailing torque type hexagon nuts with
non-metallic insert, low type
Ecrous auto-freinés hexagonaux avec insert
non-metallique, type bas
Tuercas hexagonales de autoseguro bajas,
con arandela plastica
Dadi esagonali autobloccanti tipo basso con
inserto non metallico



Abbildung	Artikel	Bezeichnung
	DIN 986	Sechskant-Hutmuttern, mit nichtmetallischem Klemmteil Prevailing torque type hexagon domed cap nuts with non-metallic insert Ecrous auto-freinés hexagonaux borgnes à callottes avec insert non-metallique Tuercas hex. de autoseguro ciegas, con arandela plastica Dadi esagonali autobloccanti a calotta cieca con inserto non metallico
	DIN 988	Passscheiben Shim rings Rondelles d'ajustage Arandelas de ajuste Rondelle di spessore
	DIN 1052	Scheiben für Holzverbindungen Washers for wood constructions Rondelles pour constuctions en bois Arandelas para construcciones de madera Rondelle per costruzioni in legno
	DIN 1440 ISO 8738	Scheiben für Bolzen, Ausführung mittel Washers for clevis pins, finish medium Rondelles plates pour tourillons Arandelas para pernos Rondelle piana per perni
	DIN 1441	Scheiben für Bolzen, Ausführung grob Washers for clevis pins, finish coarse Rondelles plates pour tourillons Arandelas para pernos Rondelle per perni
	DIN 1471 ISO 8744	Kegelkerbstifte Grooved pins; full-length taper grooved Goupilles coniques cannelées Maquitos conicos ranurados Spine coniche con intaglio
	DIN 1472 ISO 8745	Passkerbstifte Grooved pins; half-length taper grooved Goupilles cannelées d'ajustage Maquitos ranurados Spine intagliate a mezza lunghezza







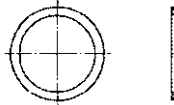
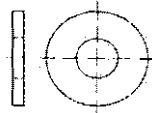
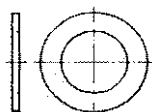
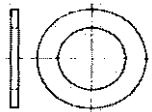
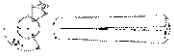

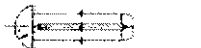

Abbildung	Artikel	Bezeichnung
	DIN 1473 ISO 8740	Zylinderkerbstifte mit Fase Grooved pins; full-length parallel grooved with chamfer Goupilles cannelées cylindrique Maquitos cilindricos ranurados Spine cilindriche con intaglio
	DIN 1474 ISO 8741	Steckkerbstifte Grooved pins; half-length reserve taper grooved Goupilles cannelées d'ajustage Maquitos cilindrico conicos ranurados Spine cilindrico-coniche con intaglio
	DIN 1476 ISO 8746	Halbrundkerbnägel Grooved pins with round head Clous cannelées à tête demi-ronde Maquitos cab. redonda ranurados Ribattini a testa tonda intagliati
	DIN 1481 ISO 8752	Spannstifte (Spannhülsen), schwere Ausführung Slotted spring pins, heavy duty Goupilles à ressort Maquitos de sejeccion-tipo pesado Spine elastiche, tipo pesante inox
	DIN 1587	Sechskant-Hutmuttern, hohe Form Hexagon domed cap nuts, high type Ecrous borgnes à calotte hexagonaux, forme haute Tuercas hexagonales ciegas Dadi ciechi a calotta
	DIN 2093	Tellerfedern Disc springs Rondelles-ressort Muelles de plato Molle a tazza
	DIN 3017-1	Schlauchschellen mit Schneckenantrieb, Form A Hose clamps Colliers de serrage Abrazaderas Fascette serratubi

Abbildung	Artikel	Bezeichnung
	DIN 6330	Sechskantmuttern 1,5 d hoch, Form B Hexagon nuts 1,5 d Ecrous hexagonaux 1,5 d Tuercas hexagonales 1,5 d Dadi esagonali 1,5 d
	DIN 6331	Sechskantmuttern 1,5 hoch, mit Bund Hexagon nuts 1,5 d with collar Ecrous hexagonaux 1,5 d à embase cylindrique Tuercas hexagonales 1,5 d con arandela Dadi esagonali 1,5 d con collare
	DIN 6334	Sechskantmuttern (Langmuttern), Höhe $m = 3 d$ Hexagon nuts, $m = 3 d$ Ecrous hexagonaux, $m = 3 d$ Tuercas hexagonales 3 d Dadi esagonali prolungati 3 d
	DIN 6796	Spannscheiben für Schraubenverbindungen Conical spring washers for bolted connections Rondelles élastiques en cuvette pour assemblages vissés Arandelas resorte Rondelle elastiche per assemblaggi a vite
	DIN 6797	Zahnscheiben Form A und J Toothed lock washers Rondelles élastiques à dents espacées Arandelas dentadas tipo A+J Rondelle dentate tipo A+J
	DIN 6798	Fächerscheiben Form A und J Serrated lock washers Rondelles élastiques à dents chevchantes Arandelas dentadas tipo A+J Rondelle dentellate tipo A+J
	DIN 6798	Fächerscheiben Form V Serrated countersunk lock washers Rondelles élastiques à dents chevchantes Arandelas dentadas tipo V Rondelle dentellate tipo V

Abbildung**Artikel****Bezeichnung**

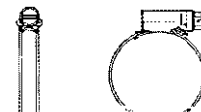
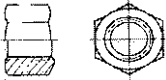
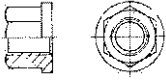
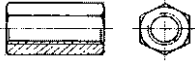
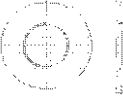
DIN 96

Halbrund-Holzschrauben mit Schlitz
Slotted round head wood screws
Vis à bois à tête ronde fendue
Tornillos para madera cab. redonda con ranura longitudinal
Viti per legno a testa tonda con taglio cacciavite

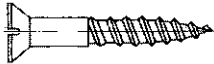

DIN 97

Senk-Holzschrauben mit Schlitz
Slotted countersunk head wood screws
Vis à bois à tête fendue fraisée
Tornillos para madera avellanados con ranura longitudinal
Viti a legno testa svasata piana taglio cacciavite

DIN 125
ISO 7089

Unterlegscheiben Form A (ohne Fase)
Plain washers (without chamfer)
Rondelles plates
Arandelas planas
Rondelle piane

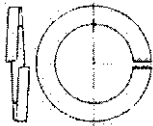

DIN 127

Federringe Form B (glatt)
Spring lockwashers
Rondelles élastiques sans becs
Arandelas helicoidal de presión
Rondelle elastice

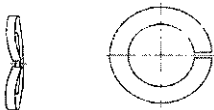

DIN 128

Federringe Form A (gewölbt)
Curved spring lock washers
Rondelles élastiques cintrées
Arandelas elasticas curvadas
Rondelle elastice ad alta tensione convessa

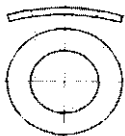

DIN 137 A

Federscheiben Form A (gewölbt)
Curved spring washers
Rondelles élastiques cintrées
Arandelas elasticas curvadas
Rondelle elastice convessa



DIN 137 B

Federscheiben Form B (gewellt)
Wave spring washers
Rondelles élastiques ondulées
Arandelas elasticas onduladas
Rondelle elastice ondulate











Abbildung	Artikel	Bezeichnung
	DIN 6799	Sicherungsscheiben (Haltescheiben) für Wellen Retaining washers for shafts Bagues de frein pour arbres Anillos de seguridad para eje Anelli radiali
	DIN 6885 A	Passfedern, hohe Form (Form A) Parallel keys Clavettes ajustées Chavetas de ajuste Chiavette ad incastro
	DIN 6912	Zylinderschrauben mit Innensechskant, niedriger Kopf, mit Schlüsselführung Socket head cap screws, low head - pilot recess Vis à tête cylindrique à six pans creux avec tête basse et trou de guidage Tornillos allen cabeza baja Viti a testa cil. con esag. incassato ribassate
	DIN 6921	Sechskantschrauben mit Flansch Hexagon flange bolts Vis métaux tête hexagonale à embase lisse Tornillos hexag. con arandela Viti a testa esagonale con flangia
	DIN 6923	Sechskantmuttern mit Flansch ohne Sperrverzahnung Hexagon flange nuts, without serration Ecrous hexagonaux à embase Tuercas hexagonales con arandela, lisca Dadi esagonali flangiati, lisci
	DIN 6923	Sechskantmuttern mit Flansch und Sperrverzahnung Hexagon flange nuts, with serration Ecrous hexagonaux à embase Tuercas hex. con arandela grafilada Dadi esagonali flangiati zigrinati
	DIN 7343 ISO 8750	Spiral-Spannstifte Spiral pins Goupilles élastiques en spirale Pasadores elasticos con espirale Spine elastiche a spirale

Abbildung	Artikel	Bezeichnung
	DIN 7349	Scheiben für Schrauben mit schweren Spannhülsen Washers for bolts with heavy type spring pins Rondelles pour vis avec goupilles élastique lourdes Arandelas para maquitos de sujecion Rondelle piane per spine elastiche
	DIN 7500 C-Z	Gewindefurchende Linsenschrauben, Form C, Kopf nach DIN 7985, Kreuzschlitz Z - Pozidrive Thread rolling raised cheese head screws - Z Vis format le filetage à tête cylindrique bombée, empreinte cruciforme - Z Tornillos trilobulares cab/cilindrica - Z Viti trilobate automaschianti a testa cilindrica - Z
	DIN 7500 M-Z	Gewindefurchende Senkschrauben, Form M, Kopf nach DIN 965, Kreuzschlitz Z - Pozidrive Thread rolling countersunk head screws - Z Vis formant le filetage à tête fraisée, empreinte cruciforme - Z Tornillos trilobulares avellanados - Z Viti trilobate automaschianti a testa svasata piana - Z
	DIN 7504 M-H	Bohrschrauben mit Linsenkopf, Form M, für Weichmetalle (z. B. Aluminium), Kreuzschlitz H - Phillips Self drilling screws with pan head - H Vis auto-percantes, tête cylindrique bombée - H Tornillos autotaladrantes c. cilindrica - H Viti autopercoranti a testa cilindrica con impronta a croce forma - H
	DIN 7504 O-H	Bohrschrauben mit Senkkopf, Form O, für Weichmetalle (z. B. Aluminium), Kreuzschlitz H - Phillips Self drilling screws with countersunk head - H Vis auto-percantes, tête fraisée - H Tornillos autotaladrantes c. avellanada - H Viti autopercoranti a testa svasata piana con impronta a croce forma - H

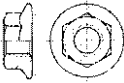
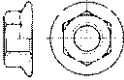
Abbildung**Artikel****Bezeichnung**

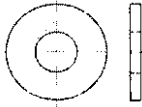
DIN
7504 K

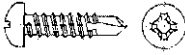
Bohrschrauben mit Sechskantkopf und Bund,
Form K, für Weichmetalle (z. B. Aluminium)
Self drilling screws with hexagon head and
flange
Vis auto-perçantes, tête hexagonale
Tornillos autotaladrantes c/hexagonal
Viti autoperforanti a testa esagonale con
bordino



DIN
7504 KO

Bohrschrauben mit Sechskantkopf und Bund,
Form K, für Weichmetalle (z. B. Aluminium)
mit aufgesteckter A2 / EPDM-Dichtscheibe
d = 16 mm
Self drilling screws with hexagon head
and flange with assembled sealing
washers 16 mm
Vis auto-perçantes, tête hexagonale
avec rondelles
Tornillos autotaladrantes c. hex. con
arandela neopreno 16 mm
Viti autop. con rondelle neoprene 16 mm

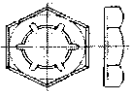

DIN 7967

Sicherungsmuttern
Self locking counter nuts
Ecrous de sécurité
Tuercas hexagonales de seguridad
Dadi esagonali autobloccanti

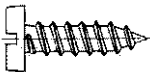

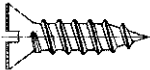

DIN
7971 C
ISO 1481

Zylinder-Blechschauben mit Schlitz
(Form C mit Spitze)
Slotted pan head tapping screws
Vis à tête cylindrique large, fendue
Tornillos para chapa cilindricos con ranura
Viti autofilet. testa cilindrica taglio cacciavite

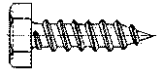
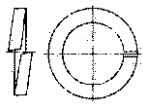
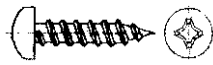
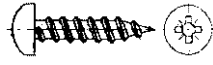

DIN
7972 C
ISO 1482

Senk-Blechschauben mit Schlitz
(Form C mit Spitze)
Slotted countersunk head tapping screws
Vis à tôle à tête fraisée, fendue
Tornillos para chapa avellanados con ranura
Viti autofilet. testa piana svasata taglio
cacciavite

Abbildung	Artikel	Bezeichnung
	DIN 7973 C ISO 1483	Linsensenk-Blechschauben mit Schlitz (Form C mit Spitze) Slotted raised countersunk head tapping screws Vis à tôle à tête fraisée bombée, fendue Tornillos para chapa gota de sebo con ranura Viti autofilet. testa svasata con calotta taglio cacciavite
	DIN 7976 C ISO 1479	Sechskant-Blechschauben (Form C mit Spitze) Hexagon head tapping screws Vis à tôle à tête hexagoanle Tornillos rosca chapa cab. hexagonal Viti autofilet. a testa esagonale
	DIN 7980	Federringe für Zylinderschrauben Spring lock washers for screws with cylindrical heads Rondelles élastiques sans becs pour vis à tête cylindrique Arandelas elasticas para tornillos cab/cil. Rondelle elastiche per viti testa cilindrica
	DIN 7981 C-H ISO 7049	Linsen-Blechschauben (Form C mit Spitze), Kreuzschlitz H - Phillips Cross recessed pan head tapping screws - H Vis à tôle à tête cylindrique bombée large à empreinte cruciforme - H Tornillos para chapa mortaja cruzada - H Viti autofilet. testa cilindrica taglio croce - H
	DIN 7981 C-Z ISO 7049	Linsen-Blechschauben (Form C mit Spitze), Kreuzschlitz Z - Pozidrive Cross recessed pan head tapping screws - Z Vis à tôle à tête cylindrique bombée large à empreinte cruciforme - Z Tornillos para chapa cab. cil. mortaja cruz. - Z Viti autofilet. testa cilindrica taglio croce - Z
	DIN 7981 C-TX ISO 7049	Linsen-Blechschauben (Form C mit Spitze), Innenvielzahn Pan head tapping screws, six lobe drive Vis tôle T.C.L., à six lobes intérieurs Tornillos para chapa cabeza cilindrica mortaja, multiestrella Viti autofilet. testa cilindrica, esalobate

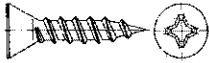
Abbildung**Artikel****Bezeichnung**

DIN 7982
C-H
ISO 7050

Senk-Blechschauben (Form C mit Spitze),
Kreuzschlitz H - Phillips
Cross recessed countersunk head tapping
screws - H
Vis à tôle à tête fraisée à empreinte
cruciforme, à bout pointu - H
Tornillos para chapa avellanadas mortaja
cruzada - H
Viti autofilet. testa piana svasata taglio
croce - H

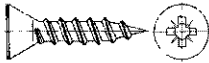

DIN 7982
C-Z
ISO 7050

Senk-Blechschauben (Form C mit Spitze),
Kreuzschlitz Z - Pozidrive
Cross recessed countersunk head tapping
screws - Z
Vis à tôle à tête fraisée à empreinte
cruciforme, à bout pointu - Z
Tornillos para chapa avellanadas mortaja
cruzada - Z
Viti autofilet. testa piana svasata taglio
croce - Z







DIN 7982
C-TX
ISO 7050

Senk-Blechschauben (Form C mit Spitze),
Innenvielzahn
Countersunk head tapping screws,
six lobe drive
Vis tôle T.F., à six lobes intérieurs
Tornillos para chapa avellanadas mortaja, multiestrella
Viti autofilet. testa piana svasata, esalobate

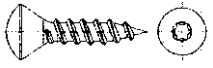

DIN 7983
C-H
ISO 7051

Linsensenk-Blechschauben
(Form C mit Spitze),
Kreuzschlitz H - Phillips
Cross recessed raised countersunk head
tapping screws - H
Vis à tôle à tête fraisée bombée à empreinte
cruciforme à bout pointu - H
Tornillos para chapa gota de sebo mortaja
cruzada - H
Viti autofilet. testa svasata con calotta taglio
croce - H

Abbildung	Artikel	Bezeichnung
	DIN 7983 C-Z ISO 7051	Linsensenk-Blechschauben (Form C mit Spitze), Kreuzschlitz Z - Pozidrive Cross recessed raised countersunk head tapping screws - Z Vis à tôle à tête fraisée bombée à empreinte cruciforme à bout pointu - Z Tornillos para chapa gota de sebo mortaja cruzada - Z Viti autofilet. testa svasata con calotta taglio croce - Z
	DIN 7983 C-TX ISO 7051	Linsensenk-Blechschauben (Form C mit Spitze), Innenvielzahn Raised countersunk head tapping screws, six lobe drive Vis tôle T.F.B., à six lobes intérieurs Tornillos para chapa gota de sebo mortaja, multiestrella Viti autofilet. testa svasata con calotta, esalobate
	DIN 7984	Zylinderschrauben mit Innensechskant und niedrigem Kopf Hexagon socket head cap screws with low head Vis à tête cylindrique à six pans creux avec tête basse Tornillos alien cabeza baja Viti a testa cilindrica con esagono incassato testa ribassata
	DIN 7985 H ISO 7045	Linsenschrauben, Kreuzschlitz H - Phillips Cross recessed raised cheese head screws - H Vis à tête cylindrique bombée à empreinte cruciforme - H Tornillos cab. cil. abombada mortaja cruz. - H Viti a testa cil. con calotta taglio croce - H
	DIN 7985 Z ISO 7045	Linsenschrauben, Kreuzschlitz Z - Pozidrive Cross recessed raised cheese head screws - Z Vis à tête cylindrique bombée à empreinte cruciforme - Z Tornillos cab. cil. abombada mortaja cruz. - Z Viti a testa cil. con calotta - Z

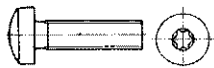
Abbildung**Artikel****Bezeichnung**

DIN
7985 TX
ISO 7045

Linsenschrauben, Innenvielzahn
Pan head screws, six lobe drive
Vis à tête cylindrique, bombée,
à six lobes intérieurs
Tornillos cab. cil. abombada mortaja,
multiestrella
Viti a testa cil. con calotta, esalobate



DIN 7989

Scheiben für Stahlkonstruktionen
Washers for steel constructions
Rondelles pour constructions en metal
Arandelas para construcciones metalicas
Rondelle di spessore

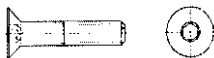

DIN 7991

Senkschrauben mit Innensechskant
Hexagon socket countersunk head screws
Vis à tête fraisée à six pans creux
Tornillos alien cabeza avellanada
Viti testa piana svasata con esagono
incassato



DIN
7991 TX

Senkschrauben, Innenvielzahn
Countersunk head screws, six lobe drive
Vis à tête fraisée à six lobes intérieurs
Tornillos allen cabeza avellanada,
multiestrella
Viti testa piana svasata, esalobate

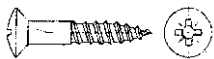

DIN
7995 Z

Linsensenk-Holzschrauben,
Kreuzschlitz Z - Pozidrive
Cross recessed raised countersunk head
wood screws - Z
Vis à bois à tête fraisée bombée avec
empreinte cruciforme - Z
Tornillos para madera gota de sebo - Z
Viti per legno a testa svasata con calotta - Z



DIN
7996 Z

Halbrund-Holzschrauben,
Kreuzschlitz Z - Pozidrive
Cross recessed round head wood screws - Z
Vis à bois à tête ronde avec empreinte
cruciforme - Z
Tornillos para madera cab. redonda - Z
Viti per legno a testa tonda - Z





Abbildung	Artikel	Bezeichnung
	DIN 7997 Z	Senk-Holzschrauben, Kreuzschlitz Z - Pozidrive Cross recessed countersunk head wood screws - Z Vis à bois à tête fraisée bombée avec empreinte cruciforme - Z Tornillos para madera avellanados - Z Viti per legno a testa svasata piana - Z
	DIN 9021 ISO 7093	Unterlegscheiben, Außendurchmesser ~ 3 x Schraubendurch- messer Washers with outside diameter ~ 3 x nominal thread diameter Rondelles, diamètre extérieur ~ 3 x diamètre nominal de filetage Arandelas ala ancha 3 d Rondelle fascia larga 3 d
	DIN 11024	Federstecker, doppelte Ausführung Cotter pins Goupilles ressort double Pasadores tipo "Beta" Copiglie tipo "Beta"
	DIN 32501/3	Schweißbolzen mit Außengewinde Welding bolts Goujons à souder avec filetage extérieur Esparragos a soldar Perni da saldare con filetto esterno
	DIN 80701	Knebelmuttern Toggle nuts Ecrous papillon Tuercas mariposa Dadi a farfalla
	DIN 80704	Korbmuttern Bow nuts Anneau pour sangle Argollas forma lira Golfari a lira



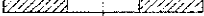

Abbildung	Artikel	Bezeichnung
	Art-Nr. 8378	Edelstahl-Drahtseil nach DIN 3053, hart 1x19 (mit 1.570 N/mm ²) Wire rope for shrouds Câbles 1x19 Cables Cavo inossidabile per sartieme
	Art-Nr. 8379	Edelstahl-Drahtseil nach DIN 3055, mittelweich 7x7 (mit 1.570 N/mm ²) Soft wire rope Câbles 7x7 Cables ductiles Cavo inossidabile per drizze
	Art-Nr. 8381	Edelstahl-Drahtseil 7x7, PVC ummantelt (mit 1.570 N/mm ²) Wire rope for guardrail Câbles Gaines 7x7 PVC Cables para guardrails Cavo inossidabile ricoperto in PVC
	Art-Nr. 8382	Edelstahl-Drahtseil nach DIN 3060, weich 7x19 (mit 1.570 N/mm ²) Wire rope for halyards, flexible Câbles 7x19 Cables para drizas Cavo inossidabile per drizze
	Art-Nr. 9044	Senkkopf-Spanplattenschrauben, Innenvielzahn und Bohrspitze, Fräsrippen, verstärkter Kopf, gleitbeschichtet Countersunk head chip board screws, six lobe drive and drilling-point, double head, waxed ribs under the head Vis auto-perçantes pour agglomérés avec tête fraisée, à six lobes intérieurs Tornillos para aglomerado punta taladrante, multiestrella Viti per pannelli agglomerati a testa svasata piana con punta perforante, esalobate

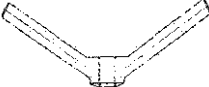



Abbildung	Artikel	Bezeichnung
	Art-Nr. 9045	<p>Rundkopf-Spanplattenschrauben, gleitbeschichtet, Innenvielzahn Pan head chipboard screws, six lobe drive Vis pour agglomérés avec tête cylindrique, à six lobes intérieurs Tornillos para aglomerado cab. cilíndrica, multiestrella Viti per pannelli agglomerati, esalobate</p>
	Art-Nr. 9046	<p>Linsensenkkopf-Spanplattenschrauben, gleitbeschichtet, Innenvielzahn Raised countersunk head chipboard screws, six lobe drive Vis pour agglomérés avec tête fraisée bombée à six lobes intérieurs Tornillos para aglomerado gota de sebo, multiestrella Viti per pannelli agglomerati, goccia sego esalobate</p>
	Art-Nr. 9047	<p>Senkkopf-Spanplattenschrauben, gleitbeschichtet, Innenvielzahn Countersunk head chipboard screws, six lobe drive Vis pour agglomérés avec tête fraisée, à six lobes intérieurs Tornillos para aglomerado avellanados, multiestrella Viti per pannelli agglomerati, testa piana svasata esalobate</p>
	Art-Nr. 9048	<p>Rundkopf-Spanplattenschrauben, gleitbeschichtet, Kreuzschlitz Z - Pozidrive Cross recessed pan head chipboard screws - Z Vis pour agglomérés avec tête cylindrique - Z Tornillos para aglomerado cab. cilíndrica - Z Viti per pannelli agglomerati testa cil. - Z</p>
	Art-Nr. 9049	<p>Linsensenkkopf-Spanplattenschrauben, gleitbeschichtet, Kreuzschlitz Z - Pozidrive Cross recessed raised chipboard screws - Z Vis pour agglomérés avec tête fraisée bombée - Z Tornillos para aglomerado gota sebo - Z Viti per pannelli agglomerati goccia sego - Z</p>



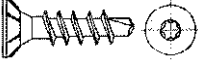

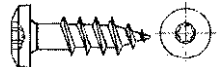
Abbildung	Artikel	Bezeichnung
	DIN 186	Hammerschrauben mit Vierkant, Form A T-head bolts with square neck Vis à tête rectangulaire à angles abattus à collet carré Tornillos cabeza martillo y cuello cuadrado Viti con testa a martello e quadro sotto testa
	DIN 188	Hammerschrauben mit Nase T-head bolts with double nib Vis à tête rectangulaire à angles abattus à deux ergots Tornillos cabeza martillo Viti con testa a martello a due griffe
	~ DIN 315	Flügelmuttern, amerikanische Form Wing nuts, american type Ecrous à oreilles, type américain Tuercas mariposa tipo americano Dado ad aletta forma americana
	DIN 315	Flügelmuttern, schwere Form Wing nuts Ecrous à oreilles Tuercas mariposa Dado ad aletta
	-DIN 316	Flügelschrauben, amerikanische Form Wing screws, american type Vis à oreilles, type américain Tornillos mariposa tipo americano Viti ad alette forma americana
	DIN 316	Flügelschrauben, schwere Form Wing screws Vis a oreilles Tornillos mariposa Viti ad alette
	DIN 404	Kreuzlochschrauben mit Schlitz Capstan screws, slotted Vis de plombage avec fente Tornillos cab. cilíndrica ranurada y con agujeros Viti a testa cilindrica

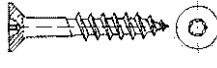



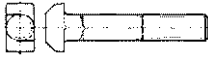

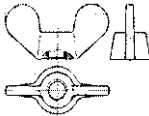
Abbildung	Artikel	Bezeichnung
	Art-Nr. 9050	Senkkopf-Spanplattenschrauben, gleitbeschichtet, Kreuzschlitz Z - Pozidrive Cross recessed countersunk chipboard screws - Z Vis pour agglomérés avec tête fraisée - Z Tornillos para aglomerado avellanado - Z Viti per pannelli agglomerati testa piana svasata - Z
	Art-Nr. 9051	Blechschauben mit Innensechskant- Zylinderkopf gem. DIN 912 Tapping screws with head DIN 912 Vis à tôle avec tête cylindrique DIN 912 Tornillos rosca chapa allen Viti autofilet. a testa cilindrica con esagono incassato
	Art-Nr. 9052	Blindnieten mit Sollbruchdorn, ähnl. DIN 7337 Form A (Flachkopf) Blindrivets, with break mandrel Rivets aveugles Remaches tubulaires Rivetti a strappo lega inox
	Art-Nr. 9053 ISO 7380	Linsenkopfschrauben mit Innensechskant Button head screws Vis à tête bombée à six pans creux Tornillos cabeza abombada hueco hexagonal Viti testa bombata cava esagonale
	Art-Nr. 9054	Karoscheiben Washers Rondelles de carrosserie Arandelas ala ancha di carroceria Rondelle fascia larga per carrozzeria
	Art-Nr. 9055	Dichtscheiben für Senkschrauben, mit EPDM-Beschichtung Sealing washers for countersunk screws Rondelles d'étanchéité Arandelas con neopreno Rondelle con guanizione in neoprene

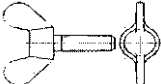
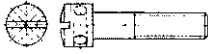



Abbildung	Artikel	Bezeichnung
	Art-Nr. 9055	Dichtscheiben für Senkschrauben, mit EPDM-Beschichtung, Kupfer Sealing washers, for countersunk screws, copper Rondelles d'étanchéité Arandelas con neopreno con bañe cobre Rondelle con guanizione ramate in neoprene
	Art-Nr. 9055	Dichtscheiben für Sechskantschrauben, mit EPDM-Beschichtung Sealing washers for hexagon bolts Rondelles d'étanchéité Arandelas con neopreno Rondelle con guanizione in neoprene
	Art-Nr. 9056	Becherschrauben NF E 27-128 Slotted mushroom head screws Vis a tête bombée, fendue Tornillos de cabeza abombada ranurada Viti testa bombata taglio cacciavite
	Art-Nr. 9057 A	Fassadenbauschrauben A (mit Spitze) mit aufgezogener U-Scheibe aus Edelstahl und aufvulkanisierter EPDM-Dichtung Self-sealing cladding screws Vis de façades Tornillos para fachada arandela 16 mm Viti perfacciate con rondelle 16 mm
	Art-Nr. 9057 BZ	Fassadenbauschrauben BZ (mit Zapfen) mit aufgezogener U-Scheibe aus Edelstahl und aufvulkanisierter EPDM-Dichtung Self-sealing cladding screws Vis de façades Tornillos para fachada arandela 16 mm Viti perfacciate con rondelle 16 mm
	Art-Nr. 9058	Gewindeeinsätze, selbstschneidend Selftapping inserts Douilles filetéés, auto-taraud age Casquillos rosca autocollante Inserti autofilettanti

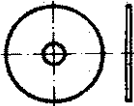



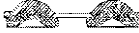

Abbildung	Artikel	Bezeichnung
	Art-Nr. 9059 A	Fassadenbauschrauben A (mit Spitze) mit aufgezogener U-Scheibe aus Edelstahl und aufvulkanisierter EPDM-Dichtung Self-sealing cladding screws Vis de façades Tornillos para fachada arandela 19 mm Viti per facciate con rondelle 19 mm
	Art-Nr. 9059 BZ	Fassadenbauschrauben BZ (mit Zapfen) mit aufgezogener U-Scheibe aus Edelstahl und aufvulkanisierter EPDM-Dichtung Self-sealing cladding screws Vis de façades Tornillos para fachada arandela 19 mm Viti per facciate con rondelle 19 mm
	Art-Nr. 9060	Anschweißmuttern, Ausführung A Schweifibuckel-Richtung unten Weld-on nuts - A Ecrous souder entièrement filetés - A Tuercas para soldar - A Piastrine a saldare - A
	Art-Nr. 9061	Hülsmuttern mit Schlitz, Linsensenkopf Sleeve nuts, threaded inside Ecrous à douille fendus Tornillos agujeros ranurados Bussole taglio cacciavite
	Art-Nr. 9063	Scharnierbandschrauben, Kopf 0 5,0 mm Hinge tape chipboardscrews, head 5,0 mm Vis Agglo. T.F pour charnieres Tornillos para gozne Viti truciolare per cerniere
	Art-Nr. 9064	Setzmuttern Insert-press nuts Ecrous a sertir, six pans Tuercas de clavar Dadi da pressare esagonali
	Art-Nr. 9065	Blechschauben mit Kappenkopf, ähnlich DIN 7981, Kreuzschlitz H - Phillips Self tapping screws with caphead, similar DIN 7981 Vis à tôle avec tête de calotte Tornillos para chapa cab. cilíndrica Viti autofilettanti con testa cilindrica

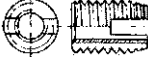
Abbildung	Artikel	Bezeichnung
	Art-Nr. 9066	Fensterbankschrauben mit Blechschraubengewinde fertig montiert mit Polyamid-Unterlegscheiben, Kappenkopf ähnl. DIN 7981, Kreuzschlitz Z - Pozidrive Special-screws for window boards mounted with polyamid-washers, selftapping thread - Z Vis spéciales pour fenêtres montée avec rondelles polyamid en version: filetage vis tôle - Z Tornillos para ventanas en varios colores - Z Viti per infissi diversi colori - Z
	Art-Nr. 9067	Spenglerschrauben / 15 (DIN 7995 Z mit aufvulkanisierter EPDM- Dichtscheibe, fertig montiert) Cross recessed raised countersunk head wood screws (DIN 7995 Z) + sealing washers Vis bois (DIN 7995 Z) avec rondelle EPDM Tirafondos gota sebo (DIN 7995 Z) + arandelas Viti a legno (DIN 7995 Z) + rondelle (2- oder 3-teilig, verkupfert oder blank)
	Art-Nr. 9068	Spenglerschrauben / 20 (DIN 7995 Z mit aufvulkanisierter EPDM- Dichtscheibe, fertig montiert) Cross recessed raised countersunk head wood screws (DIN 7995 Z) + sealing washers Vis bois (DIN 7995 Z) avec rondelle EPDM Tirafondos gota sebo (DIN 7995 Z) + arandelas Viti a legno (DIN 7995 Z) + rondelle (2- oder 3-teilig, verkupfert oder blank)
	Art-Nr. 9069	Spenglerschrauben / 25 (DIN 7995 Z mit aufvulkanisierter EPDM- Dichtscheibe, fertig montiert) Cross recessed raised countersunk head wood screws (DIN 7995 Z) + sealing washers Vis bois (DIN 7995 Z) avec rondelle EPDM Tirafondos gota sebo (DIN 7995 Z) + arandelas Viti a legno (DIN 7995 Z) + rondelle (2- oder 3-teilig, verkupfert oder blank)

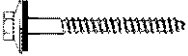

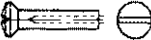

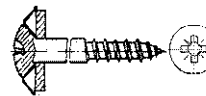
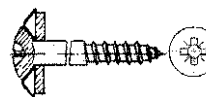
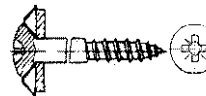

Abbildung**Artikel****Bezeichnung**Art-Nr.
9070Gewindemuffen mit durchgehendem
Innengewinde, runde Ausführung
Round coupler nuts
Ecrous rondes de jonction
Tuercas redondas de conexion
Manicotti cilindriciArt-Nr.
9071Gewindemuffen mit durchgehendem
Innengewinde, Sechskant-Ausführung
Hexagon coupler nuts
Ecrous hexagonaux de jonction
Tuercas hexagonales de conexion
Manicotti esagonaliArt-Nr.
9072Spannschlösser
Turnbuckles
Tendeur de serrage
Tensores
TenditoriArt-Nr.
9073Kauschen
Wire thimbles
Cosses pour cables
Guardacabos a corazón
Redancia lucidaArt-Nr.
9074Drahtseilklemmen
Wire rope clips
Serre-câbles à étrier
Grampas para cables
Morsetto per cavoArt-Nr.
9075Karabinerhaken
Spring hooks
Mousquetons
Mosquetons
MoschettoneArt-Nr.
9076Rundschäkel, kurze Form
Shackle straight "D"
Manilles Droite
Grilletes rectos tipo "D"
Grilli diritti a "D"Art-Nr.
9077Kettenotglied
Quick link for chains
Maillon Rapides
Eslabones de unión
Maglie rapide di giunzione

Abbildung	Artikel	Bezeichnung
	Art-Nr. 9078	Ösenschauben mit metrischem Gewinde Screw eyes Pitons à Oeil filetage métrique Hembrillas cerradas rosca metrica Occhioli a vite per legno
	Art-Nr. 9079	Ôsenschauben mit Holzgewinde Screw eyes Pitons à Oeil filetage bois Hembrillas cerradas rosca madera Occhioli a vite per legno
	Art-Nr. 9080	Wäscheleinehaken Clothes-line-hooks Pitons Ouverts filetage bois Ganchos roscados Ganci a vite per legno
	Art-Nr. 9081	Rosetten, Vollmetall NF E 27-619 Rosetten turned full body, 90° Rondelles cuvettes usince Arandelas conicas ovalillo Rondelle coniche
	Art-Nr. 9082	Stockschrauben mit Holz- und ISO-Gewinde Dowel screws with wood- and ISO-thread Vis sans tête avec filetage à bois et métaux (ISO) Tornillos a dos roscas Viti di giunzioni a due filetti
	Art-Nr. 9083	Türbandschrauben, Rundkopf, Innenvielzahn Hinge-strip screws Vis de peinture Tornillos para gozne Viti perfissaggio cerniere
	Art-Nr. 9084	Linsenkopfschrauben mit Innensechskant und Flansch ISO 7380 F Flange button head socket screws Vis à creux, tête bombée à embase Tornillos cabeza redonda con reborde Viti testa bombata c. es. flangiata

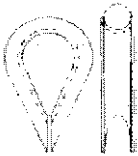
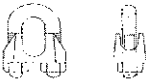
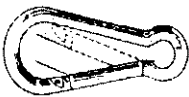
Abbildung**Artikel****Bezeichnung**

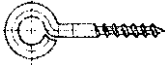
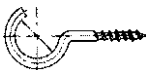
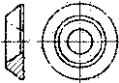
Art-Nr.
9085

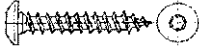
Kombimuttern mit beweglicher Scheibe
Comby-nuts
Ecrous sertis sur rondelle
Tuercas COMBY
Dadi esagonali combi con rondella conica
assemblata

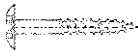

Art-Nr.
9086

Fassadenschrauben "Trespo"
mit Innenvielzahn TX 20
Thrushead screws for wood constructions -
TX 20
Vis de facades - TX 20
Tornillos para fachada - TX 20
Viti per facciate - TX 20

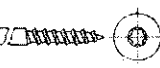

Art-Nr.
9087

Spenglerschrauben / 15
(DIN 7995 TX mit aufvulkanisierter EPDM-
Dichtscheibe, fertig montiert), Innenvielzahn
Raised countersunk head wood screws
(DIN 7995 TX) + sealing washers,
six lobe drive
Vis bois (DIN 7995 TX) avec rondelle EPDM,
à six lobes intérieurs
Tirafondos gota sebo multiestrella
+ arandelas
Viti a legno goccia sego esalobate
+ rondelle
(2- oder 3-teilig, verkupfert oder blank)

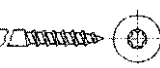

Art-Nr.
9088

Spenglerschrauben / 20
(DIN 7995 TX mit aufvulkanisierter EPDM-
Dichtscheibe, fertig montiert), Innenvielzahn
Raised countersunk head wood screws
(DIN 7995 TX) + sealing washers,
six lobe drive
Vis bois (DIN 7995 TX) avec rondelle EPDM,
à six lobes intérieurs
Tirafondos gota sebo multiestrella
+ arandelas
Viti a legno goccia sego esalobate
+ rondelle
(2- oder 3-teilig, verkupfert oder blank)

Abbildung	Artikel	Bezeichnung
	Art-Nr. 9089	Spenglerschrauben / 25 (DIN 7995 TX mit aufvulkanisierter EPDM-Dichtscheibe, fertig montiert), Innenvielzahn Raised countersunk head wood screws (DIN 7995 TX) + sealing washers, six lobe drive Vis bois (DIN 7995 TX) avec rondelle EPDM, à six lobes intérieurs Tirafondos gota sebo multiestrella + arandelas Viti a legno goccia sego esalobate + rondelle (2- oder 3-teilig, verkupfert oder blank)
	Art-Nr. 9090	Schrauben für Thermoplaste (TP) mit Senkkopf, Kreuzschlitz H - Phillips TP-screws, countersunk head cross recessed - H Vis - TP-à tête fraisée avec empreinte cruciforme - H Tornillos para plástico cab. avellanada (TP)-H Viti per plastica a testa svasata piana (TP) - H
	Art-Nr. 9091	Schrauben für Thermoplaste (TP) mit Linsenkopf, Kreuzschlitz H - Phillips TP-screws, pan head, cross recessed - H Vis - TP-à tête bombée avec empreinte cruciforme - H Tornillos para plástico cab. cil. (TP) - H Viti per plastica a testa bombata (TP) - H
	Art-Nr. 9092	Fassadenschrauben, HI-LO Gewinde und Zentrierspitze, Kreuzschlitz H - Phillips Cladding screws, HI-LO thread and center point - H Vis de Bardage Double Filet - H Tornillos para fachada (HI-LO) - H Viti perfacciate (HI-LO) - H
	Art-Nr. 9093	Schnorr-Sicherungsscheiben "S" Schnorr safety-washers type "S" Rondelles de sécurité "S" Arandelas de seguridad "S" Rondelle di sicurezza "S"

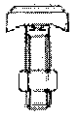
Abbildung**Artikel****Bezeichnung**

Art-Nr.
9094

Ankerschienenschrauben für Profil 50/30
mit Sechskantmutter nach DIN 934
Hammerhead screws for special purposes
Vis de Suspension avec écrou hexagonal
Tornillos cabeza guía para perfiles con tuerca
hexagonal
Viti di sospensione per profili con dado
esagonale

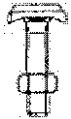

Art-Nr.
9095

Ankerschienenschrauben für Profil 40/22
mit Sechskantmutter nach DIN 934
Hammerhead screws for special purposes
Vis de Suspension avec écrou hexagonal
Tornillos cabeza guía para perfiles con tuerca
hexagonal
Viti di sospensione per profili con dado
esagonale

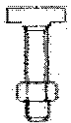

Art-Nr.
9096

Ankerschienenschrauben für Profil 38/17
mit Sechskantmutter nach DIN 934
Hammerhead screws for special purposes
Vis de Suspension avec écrou hexagonal
Tornillos cabeza guía para perfiles con tuerca
hexagonal
Viti di sospensione per profili con dado
esagonale

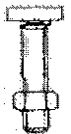

Art-Nr.
9097

Ankerschienenschrauben für Profil 28/15
mit Sechskantmutter nach DIN 934
Hammerhead screws for special purposes
Vis de Suspension avec écrou hexagonal
Tornillos cabeza guía para perfiles con tuerca
hexagonal
Viti di sospensione per profili con dado
esagonale



NF E
25-511







AFNOR-Kontaktscheiben, Form M
AFNOR contact washers, type M
Rondelles de serrage AFNOR
Arandelas estriadas AFNOR
Rondelle zigrinate AFNOR



NF E
25-514

AFNOR-Scheiben
AFNOR washers
Rondelles AFNOR
Arandelas AFNOR
Rondelle AFNOR



Abbildung	Artikel	Bezeichnung
	Art-Nr. 130050 - 137960	Metrische Schrauben mit ZWEILOCH-ANTRIEB, Linsenkopf, Panhead Security screws TWO-HOLE-DRIVE Vis métaux TC-2 trous Tornillos de seguridad cabeza cilíndrica 2 agujeros Viti metallo testa cilindrica a 2 fori
	Art-Nr. 130050 - 137960	Metrische Schrauben mit ZWEILOCH-ANTRIEB, Senkkopf, Flathead Security screws TWO-HOLE-DRIVE Vis métaux TF-2 trous Tornillos de seguridad cabeza avellanada 2 agujeros Viti metallo testa svasata piana a 2 fori
	Art-Nr. 130050 - 137960	Blechschauben mit ZWEILOCH-ANTRIEB, Linsenkopf, Panhead Security screws TWO-HOLE-DRIVE Vis tole TC-2 trous Tornillos de seguridad cabeza cilíndrica 2 agujeros Viti atf. testa cilindrica a 2 fori
	Art-Nr. 130050 - 137960	Blechschauben mit ZWEILOCH-ANTRIEB, Senkkopf, Flathead Security screws TWO-HOLE-DRIVE Vis tôle TF-2 trous Tornillos de seguridad cabeza avellanada 2 agujeros Viti atf. testa svasata piana a 2 fori
	Art-Nr. 130050 - 137960	Blechschauben mit ZWEILOCH-ANTRIEB, Flachrundkopf, Trusshead Security screws TWO-HOLE-DRIVE Vis tole tete bombée-2 trous Tornillos de seguridad cabeza redonda 2 agujeros Viti atf. testa tonda a 2 fori
	Art.-Nr. 130050 - 137960	Blechschauben mit ZWEILOCH-ANTRIEB, Linsensenkkopf, Ovalhead Security screws TWO-HOLE-DRIVE Vis tôle TFB-2 trous Tornillos de seguridad cabeza gota sebo 2 agujeros Viti atf. testa bombata a 2 fori



DIN 417
ISO 7435

Gewindestifte mit Schlitz und Zapfen
Slotted set screws with long dog point
Vis sans tête, fendues, à téton long
Esparragos ranurados
Viti senza testa con intaglio e punta cilindrico



DIN 427
ISO 2342

Schaftschrauben mit Schlitz und Kegelkuppe
Slotted headless screws with chamfered end
Vis sans tête, partiellement filetées, à bout chanfrainé
Esparragos ranurados rosca parcial
Viti senza testa parzialmente filettate

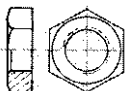

DIN 431 B

Rohrmuttern Form B, Rohrgewinde nach DIN ISO 228
Pipe nuts
Ecrous six pans, filet à gaz
Tuercas hexagonales roscadas para tubos
Dadi esagonali filettatura gas

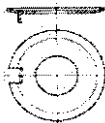

DIN 432

Sicherungsbleche mit Nase
Washers with external tab
Freins d'écrous avec ergot extérieur
Arandelas de seguro con lengüeta
Placchette di sicurezza con nasello esterno

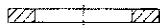

DIN 433
ISO 7092

Unterlegscheiben für Zylinderschrauben
Washers for cheese head screws
Rondelles pour vis à tête cylindrique
Arandelas para tornillos de cab. cilíndrica
Rondelle piane per viti a testa cilindrica

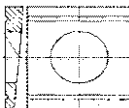

DIN 434

Keilscheiben für U-Träger, Neigung 8%
Square taper washers for U-sections
Plaque oblique pour profilés en U
Arandelas cuadradas en cuna para perfiles U
Piastrine quadre per profili a U



DIN 435

Keilscheiben für I-Träger, Neigung 14%
Square taper washers for I-sections
Plaque oblique pour profilés en I
Arandelas cuadradas en cuna para perfil I
Piastrine quadre per profili a I

Abbildung**Artikel****Bezeichnung**

Art-Nr.
130050 -
137960

Metrische Schrauben (ISO 7380) mit INNEN-SECHSKANT und SICHERHEITS-PIN, Flachrundkopf, Buttonhead
Security screws PIN-HEXAGON
Vis métaux tête bombée HC + Téton
Tornillos de seguridad cabeza redonda hexagono interior + pivote
Viti metallo testa tonda esagono incassato + piolino



Art-Nr.
130050 -
137960

Metrische Schrauben (DIN 7991) mit INNEN-SECHSKANT und SICHERHEITS-PIN, Senkkopf, Flathead
Security screws PIN-HEXAGON
Vis métaux TFHC + Téton
Tornillos de seguridad cabeza avellanada hexagono interior + pivote
Viti metallo testa svasata piana esagono incassato + piolino



Art-Nr.
130050 -
137960

Blechschauben mit INNENSECHSKANT und SICHERHEITS-PIN, Flachrundkopf, Buttonhead,
Security screws PIN-HEXAGON
Vis tole tete bombée 6 pans creux + Téton
Tornillos de seguridad cabeza redonda hexag. interior + pivote
Viti aff. testa tonda esagono incassato + piolino







Art-Nr.
130050 -
137960

Blechschauben mit INNENSECHSKANT und SICHERHEITS-PIN, Senkkopf, Flathead
Security screws PIN-HEXAGON
Vis tôle TF 6 Pans creux + Téton
Tornillos de seguridad cabeza avellanada hexagono interior + pivote
Viti aff. testa svasata piana esagono incassato + piolino



Art-Nr.
130050 -
137960

Metrische Schrauben (ISO 7380) mit INNEN-VIELZAHN und SICHERHEITS-PIN, Flachrundkopf, Buttonhead
Security screws PIN-TX
Vis métaux tete bombée TX + Téton
Tornillos de seguridad cabeza redonda TX + pivote
Viti metallo testa tonda TX + piolino

Abbildung	Artikel	Bezeichnung
	Art-Nr. 130050 - 137960	Metrische Schrauben (DIN 7991) mit INNEN-VIELZAHN und SICHERHEITS-PIN, Senkkopf, Flathead Security screws PIN-TX Vis métaux TF TX + Téton Tornillos de seguridad cabeza avellanada TX + pivote Viti metallo testa svasata piana TX + piolino
	Art-Nr. 130050 - 137960	Blechschrauben mit INNENVIELZAHN und SICHERHEITS-PIN, Flachrundkopf, Buttonhead Security screws PIN-TX Vis tôle tête bombée TX + Téton Tornillos de seguridad gota sebo TX + pivote Viti atf. testa bombata TX + piolino
	Art-Nr. 130050 - 137960	Blechschrauben mit INNENVIELZAHN und SICHERHEITS-PIN, Senkkopf, Flathead Security screws PIN-TX Vis tôle TF TX + Téton Tornillos de seguridad cabeza avellanada TX + pivote Viti atf. testa svasata piana TX + piolino
	Art-Nr. 130050 - 137960	Metrische Schrauben mit EINWEG-ANTRIEB, Halbrundkopf, Roundhead Security screws ONEWAY Vis métaux TC fente SENS UNIQUE Tornillos de seguridad cabeza cilindrica ONE WAY Viti atf. testa cilindrica taglio a senso unico
	Art-Nr. 130050 - 137960	Blechschrauben mit EINWEG-ANTRIEB, Halbrundkopf, Roundhead Security screws ONEWAY Vis tôle TC fente SENS UNIQUE Tornillos de seguridad cabeza cilindrica ONE WAY Viti atf. testa cilindrica taglio a senso unico

Abbildung**Artikel****Bezeichnung**

Art-Nr.
130050 -
137960

Blechschauben mit EINWEG-ANTRIEB,
Linsensenkopf, Ovalhead
Security screws ONEWAY
Vis tôle TFB fente SENS UNIQUE
Tornillos de seguridad cabeza
avellanada ONE WAY
Viti aff. testa svasata piana taglio a senso
unico



Art-Nr.
130050 -
137960

Metrische Schrauben (ISO 7380) mit
SCHLIEßKOPF, Flachrundkopf, Buttonhead
Hexagon socket screws with plug
Vis métaux bombée HC avec bouchon
à téton blocage au marteau
Tornillos ISO 7380 con tapón de
seguridad
Viti testa bombata cava esagonale con
placchetta di sicurezza







Art-Nr.
138630 -
138960

Metrische Schrauben (DIN 7991) mit
SCHLIEßKOPF, Senkkopf,
Countersunk-head
Hexagon socket screws with plug
Vis métaux bombée HC avec bouchon
à téton blocage au marteau
Tornillos DIN 7991 con tapón de
seguridad
Viti testa bombata cava esagonale con
placchetta di sicurezza



Art-Nr.
134109 -
134141

Abreissmuttern
Inviolable nuts
Ecrous autocassants
Tornillos inviolables
Dadi antisvitamento

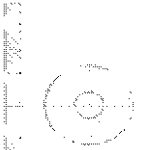
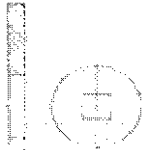
Abbildung	Artikel	Bezeichnung
	DIN 436	Vierkantscheiben für Holzkonstruktionen Square washers for wood constructions Rondelles carrées pour constructions en bois Arandelas cuadradas para constr. madera Piastrine quadre per costruzioni in legno
	DIN 438 ISO 7436	Gewindestifte mit Schlitz und Ringschneide Slotted set screws with cup point Vis sans tete, fendues, á bout cuvette Esparragos ranurados con punta biselada Grani con intaglio e punta smussata
	DIN 439 ISO 4035	Sechskantmuttern, niedrige Form, Form B (mit Fase) Hexagon thin nuts Ecrous bas hexagonaux Tuercas hexagonales bajas Dadi esagonali bassi
	DIN 439 ISO 4035	Sechskantmuttern, niedrige Form, Feingewinde, Form B (mit Fase) Hexagon thin nuts, fine pitch Ecrous bas hexagonaux, filet fin métrique Tuercas hexagonales bajas, rosca fina Dadi esagonali bassi, passo fine
	DIN 439 ISO 4035	Sechskantmuttern, niedrige Form, Linksgewinde, Form B (mit Fase) Hexagon thin nuts left hand thread Ecrous bas hexagonaux à gauche Tuercas hexagonales bajas, rosca izquierda Dadi esagonali bassi, filettatura sinistra
	DIN 440 R	Scheiben für Holzkonstruktionen, Form R = Rundloch Washers, especially for wood constructions Rondelles, principalement pour constructions en bois Arandelas para construcciones madera Rondelle per costruzioni in legno
	DIN 440 V	Scheiben für Holzkonstruktionen, Form V = Vierkantloch Washers, especially for wood constructions Rondelles, principalement pour constructions en bois Arandelas para construcciones madera Rondelle per costruzioni in legno

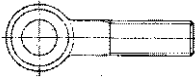
Abbildung**Artikel****Bezeichnung**

DIN 444 B Augenschrauben, Form B
Eye bolts
Vis à oeillet
Tornillos de ojo
Tirante ad occhio

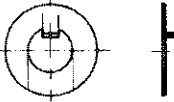

DIN 462 Sicherungsbleche mit Innennase
für Nutmuttern DIN 1804
Tabwashers with internal tab
for nuts DIN 1804
Rondelles à ergot intérieur
pourécrous raines selon DIN 1804
Arandelas de seguridad con solapa interior
para tuercas DIN 1804
Placchette di sicurezza perghiera di
blaccaggio DIN 1804

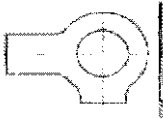

DIN 463 Sicherungsbleche mit 2 Lappen
Tabwashers with 2 tabs
Freins d'écrous à 2 ailerons d'équerre
Arandelas de seguridad con 2 solapas
Placchette di sicurezza con due linguette

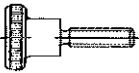

DIN 464 Rändelschrauben, hohe Form
Knurled thumb screws, high type
Vis moletées, type haut
Tornillos moleteados tipo alto
Viti alte zigrinate

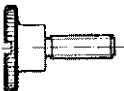

DIN 465 Rändelschrauben, hohe Form, mit Schlitz
Knurled thumb screws, high type, slotted
Vis moletées, type haute, avec fente
Tornillos moleteados ranurados, tipo alto
Viti alte zigrinate t. cacciavite

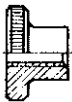

DIN 466 Rändelmuttern, hohe Form
Knurled thumb nuts, high type
Ecrous moletées, type haut
Tuercas moleteadas, tipo alto
Dadi alti zigrinati

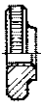

DIN 467 Rändelmuttern, niedrige Form
Knurled thumb nuts, thin type
Ecrous moletées, type bas
Tuercas moleteadas, tipo bajo
Dadi bassi zigrinati





Abbildung	Artikel	Bezeichnung
	DIN 471	Sicherungsringe für Wellen Retaining rings for shafts Circlips extérieurs Anillos para eje Anelli esterni
	DIN 472	Sicherungsringe für Bohrungen Retaining rings for bores Circlips intérieurs Anillos para taladro Anelli interni
	DIN 546	Schlitzmuttern Slotted round nuts Ecrous cylindriques á fente Tuercas redondas con ranura Dadi cilindrici con intaglio
	DIN 551 ISO 4766	Gewindestifte mit Schlitz und Kegelkuppe Slotted set screws with flat point Vis sans tête avec fente et chanfrein Esparragos ranurados con punta biselada Grani con intaglio e punta piana
	DIN 553 ISO 7434	Gewindestifte mit Schlitz und Spitze Slotted set screws with cone point Vis sans tête avec fente et pointe Esparragos ranurados con punta conica Grani con intaglio e punta conica
	DIN 557	Vierkantmuttern Square nuts Ecrous carrés Tuercas cuadradas Dadi quadri
	DIN 562	Vierkantmuttern, niedrige Form Square thin nuts Ecrous carrés bas Tuercas cuadradas bajas Dadi quadri bassi
	DIN 571	Sechskant-Holzschrauben Hexagon head wood screws Vis à bois à tête hexagonale Tornillos para madera cabeza hexagonal Viti a legno testa esagonale





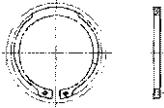
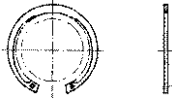
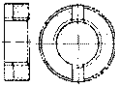

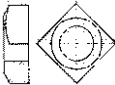
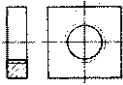

Abbildung	Artikel	Bezeichnung
	Art-Nr. 572	Sechskant-Holzschrauben mit Flansch Hexagon wood screws with flange Vis bois T.H à embase Tornillos para madera cab. hex. con arandela Viti per legno a testa esagonale con flangia
	DIN 580	Ringschrauben Lifting eye bolts Vis à anneau Tornillos de caicamo Golfaro ad occhio con gambo filettato
	DIN 582	Ringmuttern Lifting eye nuts Ecrous à anneau Tornillos de caicamo Golfari femmina
	DIN 603 ISO 8677	Flachrundschrauben mit Vierkantansatz Mushroom head square neck bolts Vis à tete bombée à collet carré Tornillos aplastados con cuello cuadrado Viti testa tonda quadro sotto testa
	DIN 653	Rändelschrauben, niedrige Form Knurled thumb screws, thin type Vis moletées, type bas Tornillos moleteados, tipo bajo Viti basse zigrinate
	DIN 660	Halbrundnieten Round head rivets Rivets à tete ronde Remaches con cabeza redonda Ribattini a testa tonda
	DIN 661	Senknieten Countersunk head rivets Rivets à tête fraisée Remaches con cabeza avellanada Ribattini a testa svasata
	DIN 705	Stellringe Form A, mit Gewindestiften DIN 914 Adjusting rings Bagues d'arrêt Anillos de ajuste Anello d'arresto

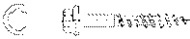
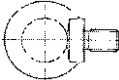
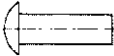
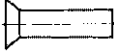
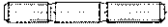
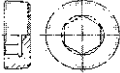
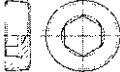
Abbildung	Artikel	Bezeichnung
	DIN 763	Rundstahlketten, langgliedrig Round long link chains Chaînes à maillons longs Cadenas Catena a maglia lunga
	DIN 766	Rundstahlketten, kurzgliedrig Round short link chains Chaînes à maillons courts Cadenas Catena a maglia corta
	DIN 835	Stiftschrauben, Einschraubende ~ 2 d Studs, metal end ~ 2 d Goujons-partie filetée e ~ 2 d Esparragos-parte roscada e ~ 2 d Viti prigionere senza sede fissa all 'estremità d'avvitamento ~ 2 d
	DIN 906	Verschlusschrauben mit Innensechskant, kegeliges Gewinde metrisch nach DIN 158 Hexagon socket pipe plugs, conical thread according to DIN 158 Bouchons filetés à six pans creux, filetage conique à la DIN 158 Tapones cónicos con hexagono interior según DIN 158 Tappi conici con esagono incassato secondo DIN 158
	DIN 906	Verschlusschrauben mit Innensechskant, kegeliges WHITWORTH Rohrgewinde nach DIN 3858 Hexagon socket pipe plugs, conical thread according to DIN 3858 Bouchons filetés à six pans creux, filetage conique à la DIN 3858 Tapones cónicos con hexagono interior según DIN 3858 Tappi conici con esagono incassato secondo DIN 3858